

Exhibit Space & Booth Layout Guidelines

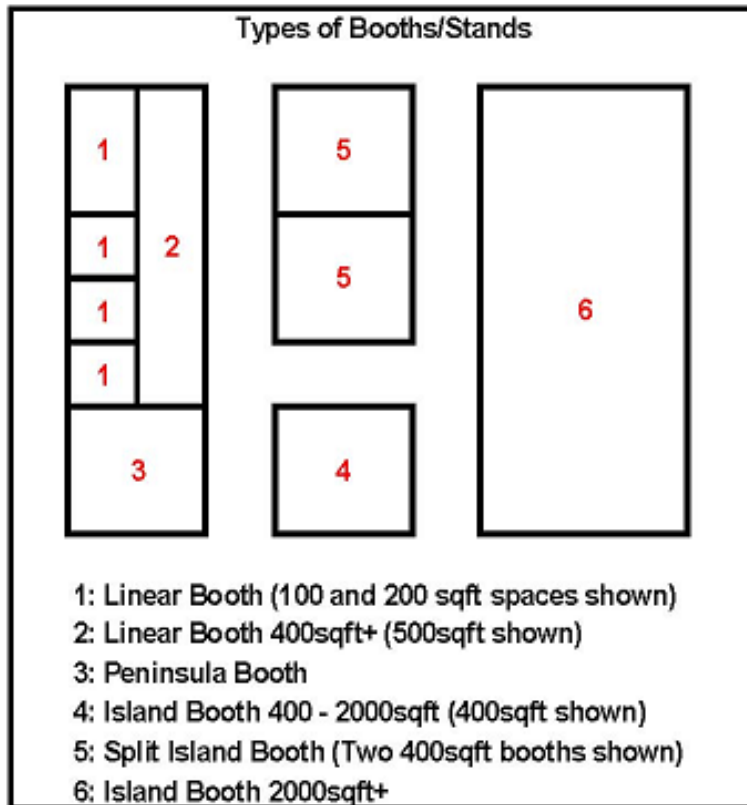

Exhibit Space & Booth Display Rules
The following display rules have been designed using the IAEE (International Association of Exhibitions and Events) guidelines and modified to incorporate some of the needs of the many International exhibitors who are present at PennWell exhibitions. Every attempt has been made to maintain fairness to exhibitors in booths of all sizes and to maintain clear lines of sight to neighboring booths. These rules will be enforced in the exhibit hall and you must have written approval from PennWell to display anything that does not adhere to the limits set forth in this document. Please contact your [Exhibit Services Manager](#) if you have any questions regarding these display rules.

General notes:

- Flooring in your exhibit space is mandatory but not provided with your exhibit space purchase. If you are not providing your own flooring for your booth, you must rent carpet from the show's General Service Contractor. Please refer to the Exhibitor Manual for more information
- Under no circumstances may machinery or any part of an exhibitor's display extend outside of the boundary of said exhibitor's contracted exhibit space regardless of the height clearance from the floor of said item. This rule also applies to lights, speakers, and hanging signs.
- Show Management reserves the right to "force carpet" any exhibit area that is without flooring within two hours before the end time for booth move-in/setup. Exhibitor is responsible for the flooring cost.
- To maintain a professional appearance of the exhibit hall, booths must have back sides of displays covered when visible from an aisle (eg: panels on the back side of a pop-up structure in an island booth to cover the frame).
- Utility connections (electrical or internet wires, air/water/gas hoses, etc) must be hidden from view in order to maintain a high level of safety and professional appearance.
- Unless explicitly contracted with Show Management, booth spaces are unfurnished. Please refer to Exhibitor Manual to rent booth furniture.

EXHIBIT BOOTH EXAMPLES

Linear Booth

Linear Booths have only one side exposed to an aisle and are generally arranged in a series along a straight line. They are also called “in-line” booths.

Dimensions

To maintain consistency and for ease of layout and/or reconfiguration, floor plan design in increments of 10 ft (3.05m) has become the standard. Therefore, Linear Booths are most commonly 10 ft (3.05m) wide and 10 ft (3.05m) deep (10' x 10').

Maximum backwall height limit: 8 ft (2.5m)

Use of Space

Regardless of the number of Linear Booths utilized, display materials should be arranged in such a manner so as not to obstruct sight lines of neighboring exhibitors. The maximum height of 8 ft (2.44m) is allowed only in the rear half of the booth space, with a 3 ft (0.91m) height restriction imposed on all materials in the remaining space forward to the aisle.

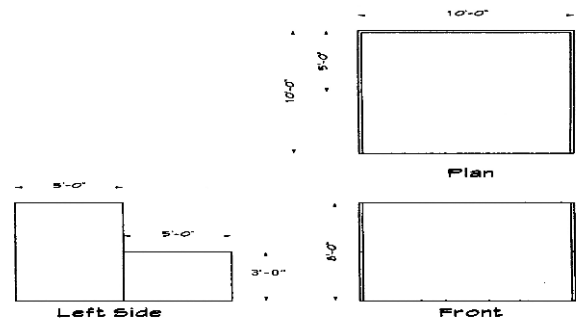
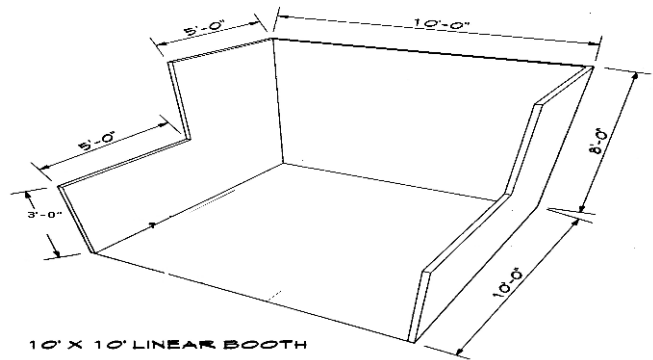

Corner Booth

A Corner Booth is a Linear Booth exposed to aisles on two sides. All other guidelines for Linear Booths apply.

Perimeter Booth

A Perimeter Booth is simply a Linear Booth that backs to a wall of the exhibit facility rather than to another exhibit.

Dimensions and Use of Space

All guidelines for Linear Booths apply to Perimeter Booths except that the typical maximum backwall height is 12 ft (3.66m).

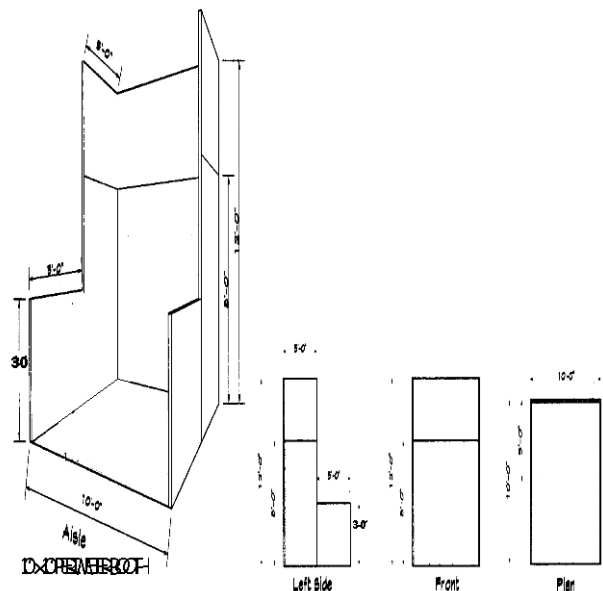

Peninsula Booth

A Peninsula Booth is exposed to aisles on three (3) sides and composed of a minimum of four (4) 10'x10' booths. There are two types of Peninsula Booths: (a) one which backs up to Linear Booths, and (b) one which backs to another Peninsula Booth and is referred to as a “Split Island Booth.”

Dimensions:

A Peninsula Booth is usually 20'x20' (6.1m x 6.1m) or larger. When a Peninsula Booth backs up to two Linear Booths, the backwall is restricted to 3 ft (0.91m) high within 5 ft (1.52m) of each aisle, permitting adequate line of sight for the adjoining Linear Booths. Overhead hanging signs or banners up to 16 ft (4.88m) may be permissible with show management approval.

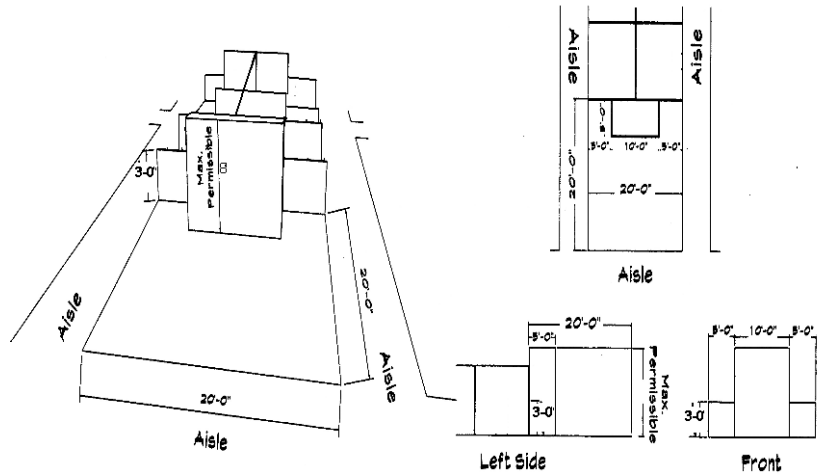

Split Island Booth

A Split Island Booth is a booth which shares a common backwall with another booth. The entire cubic content of this booth may be used, up to the maximum allowable height, without any back wall line of sight restrictions. 16 ft (4.88m) is a typical maximum height allowance, including signage. The entire cubic content of the space may be used up to the maximum allowable height.

**the minimum size requirement for a Split Island Booth is 400 sq ft.*

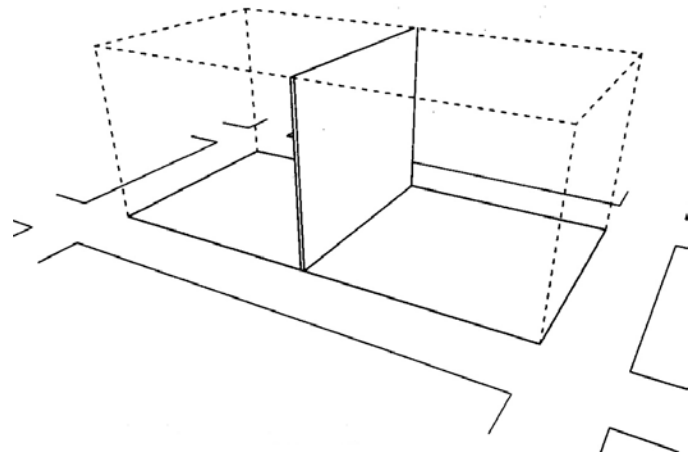

Island Booth

An Island Booth is any size booth exposed to aisles on all four sides.

Dimensions

An Island Booth is typically 20 ft x20 ft (7.75m x 7.75m) or larger, although it may be configured differently.

Use of Space

The entire cubic content of the space may be used up to the maximum allowable height, which is usually 16 ft (4.88m), including signage.

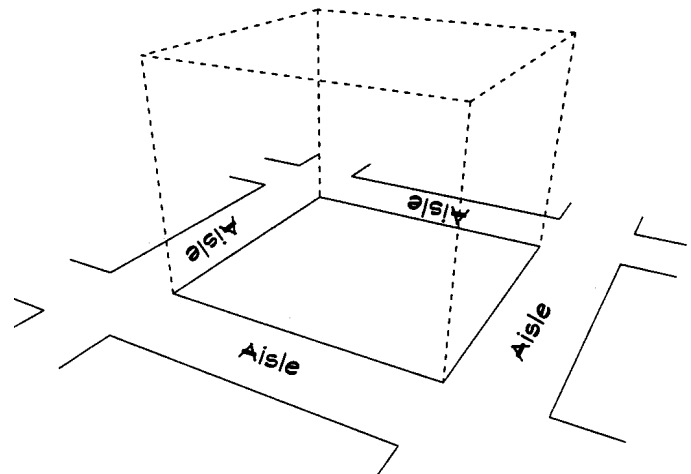

Other Important Considerations

Canopies and Ceilings

Canopies, including ceilings, umbrellas and canopy frames, can be either decorative or functional (such as to shade computer monitors from ambient light or for hanging products). Canopies for Linear or Perimeter Booths should comply with line of sight requirements (see “Use of Space for Linear or Perimeter Booths”).

The base of the Canopy should not be lower than 7ft (2.13m) from the floor within 5 ft (1.52m) of any aisle. Canopy supports should be no wider than three inches (3”). This applies to any booth configuration that has a sightline restriction, such as a Linear Booth. Fire and safety regulations in many facilities strictly govern the use of canopies, ceilings and other similar coverings. Check with the appropriate local agencies prior to determining specific exhibition rules.

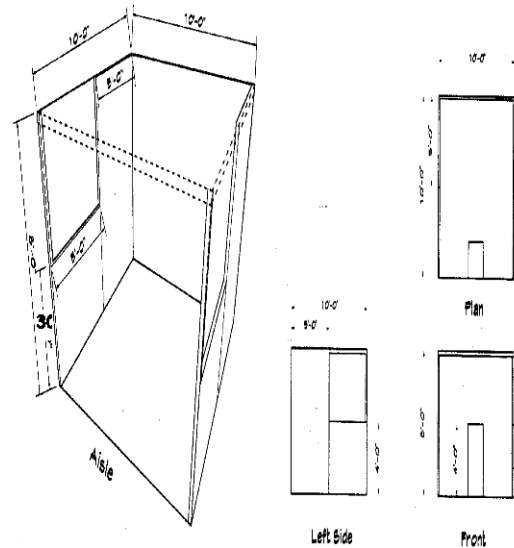

Hanging Signs & Graphics

Hanging signs and graphics may be permitted in Peninsula and Island Booths with Show Management and Venue approval, usually to a maximum height of 16 ft (4.88m). Whether suspended from above or supported from below, they should comply with all ordinary use-of-space requirements per the specific Venue Rules and Regulations (for example, the highest point of any sign should not exceed the maximum allowable height for the booth type).

Hanging Signs & Graphics should be set back 10 ft (3.05m) from adjacent booths.

Approval for the use of Hanging Signs & Graphics should be received from Show Management at least 60 days prior to installation. Drawings must be available for inspection.

Towers

A Tower is a freestanding exhibit component separate from the main exhibit fixture. The height restriction is the same as that which applies to the appropriate exhibit configuration being used.

Towers in excess of 8 ft (2.44m) must have drawings available for inspection and have Show Management and Venue approval. Fire and safety regulations in many facilities strictly govern the use of towers. A building permit may be required.

Multi-story Exhibit

A Multi-story Exhibit is a booth where the display fixtures exceed 12 ft (3.66m), including Double-decker and Triple-decker Booths. In many cities, a Multi-storied Exhibit requires prior approval by the exhibit facility and/or relevant local government agency because it is deemed to be a “structure” for building purposes. The city building department generally needs to issue a building permit based on an application and drawings prepared and submitted by a licensed architect or engineer. Exhibitors should obtain local building regulations early on to ensure that all time constraints are met.

Exhibit Space Lighting and Sound:

- Without exception, all light and sound must be contained within, and directed into, the footprint of the contracted exhibit space.
- Additional lighting may be brought in for the exhibit space however this lighting must be restricted to the contracted exhibit space. Lighting should not shine onto the aisles or into a neighbor’s exhibit space.
- Sound must not be at a level that interferes with normal levels of communication in neighboring exhibit space.



Vehicles for Indoor Displays:

Vehicles to be displayed indoors must adhere to the following guidelines and display will likely be inspected on-site by the local fire marshal.

- Gas tank must be no more than 1/8 full.
- Battery must be removed or disconnected.
- Gas tank must feature a locking cover or cover sealed with tape.
- Ignition keys removed.
- Propane or similar compressed gas tanks removed.
- A fire extinguisher must be present in any booth featuring a display vehicle.
- *Other guidelines may apply depending on the individual Venue Rules and Regulations.*

Balloons (Static and Controlled):

- Balloons filled with helium or hydrogen are not permitted (tethered or un-tethered, controlled or stationary)
- Balloons filled with air may be suspended from the ceiling in exhibits with a minimum size of 400sqft (36sqm), pending Venue approval. In this instance, these will be treated as hanging signs. Please refer to hanging sign rules in this document for additional information. This should be designed so that the balloon is stationary and will not sway in the airflow of open doors or air conditioning.
- *Other guidelines may apply depending on the individual Venue Rules and Regulations.*

Multi-Story Structures:

- Multi-story exhibits will require approval from the following:
 - 1) PennWell Show Management to ensure compliance with display rules.
 - 2) The General Service Contractor to ensure that there are no physical obstructions that will create problems during setup.
 - 3) The facility hosting the exhibition. The rules set in place by convention centers and their local fire marshals vary from city to city with regards to the level of fire alarms, sprinklers, extinguishers, etc, that are required in multi-story booths. Stamped engineering drawings will need to be submitted for approval by the fire marshal; PennWell and the General Service Contractor will need a copy of the approved booth on file before booth construction may commence.

- *Please contact PennWell Show Management for additional information and if possible include drawings or renderings of the proposed design. Show Management will determine if the proposed design works with our display rules and will forward the design to the show's General Service Contractor. The Contractor will work with the local fire marshal to give structural approval of the design.*

PLEASE NOTE: If using a non-official contractor to set-up and/or dismantle your exhibit, the required form to request for set-up by non-official contractor along with the Certificate of Insurance naming the Official General Contractor as an additional insured, must be received by the specified deadline in the Exhibitor Manual. Otherwise labor will have to be hired from the General Contractor by the non-official contractor in order for them to supervise your exhibit. These stipulations are strictly enforced to protect you, show management and the General Contractor.

Structural Integrity:

- All exhibit displays should be designed and erected in a manner that will withstand normal contact or vibration caused by neighboring exhibitors, hall laborers, or installation/dismantling equipment, such as fork- lifts. Displays should also be able to withstand moderate wind effects that may occur in the exhibit hall when freight doors are open.
- Exhibitors should ensure that any display fixtures such as tables, racks, or shelves are designed and installed properly to support the product or marketing materials to be displayed

Flammable and Toxic Materials:

- All materials used in display construction or decorating should be made of fire retardant materials and be certified as flame retardant.
- Exhibitors should be aware of local regulations regarding fire/safety and environment which must be adhered to.
- Exhibitors should dispose of any waste products they generate during the exhibition in accordance with guidelines established by the Environmental Protection Agency and the facility.

Electrical:

- All 110-volt wiring should be grounded three-wire.
- Wiring that touches the floor should be “SO” cord (minimum 14-gauge/three-wire) flat cord, which is insulated to qualify for “extra hard usage.”
- Cord wiring above floor level can be “SJ” which is rated for “hard usage.”
- Using zip cords, two-wire cords, latex cords, plastic cord, lamp cord, open clip sockets, and two wire clamp-on fixtures is not recommended and is often prohibited. Cube taps are prohibited.
- Power strips (multi-plug connectors) should be UL approved, with built-in over-load protectors.

Conducting Business outside of Exhibit Space:

- Distributing literature or promotional items outside of the contracted booth space is prohibited. If additional space is needed, please contact Show Management to purchase additional exhibit hall floor space.

Height Restrictions – Inline Booths:

- All inline booths have an 8ft (2.5 m) backwall height restriction. Hanging signs or banners cannot be higher than 8ft (2.5 m). Please contact your [Exhibit Services Manager](#) regarding any equipment or display that will be higher than 8ft (2.5 m).
- *Other guidelines may apply depending on the individual Venue Rules and Regulations.*

Line of Sight - Inline Booths:

- All inline booths must be conscious of the arrangement of display materials so as not to obstruct sight lines of neighboring exhibitors. The maximum height of 8 ft is allowed only in the rear half of the booth space, with a 3 ft (0.91m) height restriction imposed on all materials in the remaining space forward to the aisle.

Booth Storage:

- Materials may be stored behind your booth during the show however all materials stored must be masked/covered so they are not visible. A drape or cover may be ordered through the General Services Contractor.

- ***Pictures below represent unsightly booth storage and booth displays that are not allowed.***



****unsightly booth storage***



****unsightly booth storage***



**conducting business outside of exhibit space*



**unsightly booth storage*



**unauthorized storage & exposed backwall*



**exposed backwalls should be dressed in plain or neutral color*

Thank you for adhering to these display rules. Please do not hesitate to contact your [Exhibit Services Manager](#) if you have any questions regarding your exhibit. If possible, please include a graphic of your booth design with your email to assist us in answering your questions quickly and accurately.



EXAMPLE

Booth Violation

Dear Exhibitor, your booth has the following violation(s) based on the 'event name' rules and regulations:

- ❑ **Height Restriction**
- ❑ **Line of Site Violation**
- ❑ **No Carpet**
- ❑ **Other:** _____

Please remove the violation before the start of the show on 'date.'

Please visit booth #0000 if you have any questions regarding the violation(s).

Thank you for your participation.

'Event name'