



Exhibit Space & Booth Display Guidelines

The following display rules have been designed using the **IAEE (International Association of Exhibitions and Events)** guidelines and modified to incorporate some of the needs of the many International exhibitors who are present at PennWell exhibitions. Every attempt has been made to maintain fairness to exhibitors in booths of all sizes and to maintain clear lines of sight to neighboring booths. These rules will be enforced in the exhibit hall and you must have written approval from PennWell to display anything that does not adhere to the limits set forth in this document. Please contact Danielle McCloud daniellem@pennwell.com +1 918-831-9821 and Sarah Davis Sdavis@pennwell.com +1 918-831-9729, if you have any questions regarding these display rules.

General Rules

- Booth space consisting of 2,500 square feet or more must send complete booth design with dimensions to show management for booth approval no less than 90 days out from the first move in day. Any modifications made to booth designs that have already been approved by show management must be re-submitted for additional approval. **No exceptions.**
- Flooring in your exhibit space is mandatory but not provided with your exhibit space purchase. If you are **not** providing your own flooring for your booth, you can rent carpet from the show's General Service Contractor (please see the online exhibitor manual for more information). Show Management reserves the right to **"force carpet"** in any exhibit area that is without flooring within *two hours* before the end time for booth move-in/setup. Exhibitor is responsible for the flooring cost.
- Under no circumstances may machinery or any part of an exhibitor's display extend outside of the boundary of your contracted exhibit space regardless of the height clearance from the floor. This rule also applies to lights, speakers, and hanging signs. If you have any type of projection in your booth, it must stay within your booth space. You cannot project onto the walls of the exhibit hall. If you do, you will be asked to remove the projection.
- To maintain a professional appearance of the exhibit hall, booths must have back sides of displays covered when visible from an aisle (e.g.; panels on the back side of a pop-up structure in an island booth to cover the frame).
- Utility connections (electrical or internet wires, air/water/gas hoses, etc.) must be hidden from view in order to maintain a high level of safety and professional appearance.
- Unless explicitly contracted with Show Management, booth spaces are unfurnished. Please refer to the online exhibitor manual for more information.
- Distributing literature or promotional items outside of the contracted booth space is **prohibited**. If additional space is needed, please contact Susie Cruz (A-J) scruz@pennwell.com or Nanci Yulico (K-Z) nancy@pennwell.com to purchase additional exhibit hall floor space.
- If your booth is located on South Street, exhibitors must fill out the Outside Exhibitor Tent Form in the exhibitor manual to receive the requirements specified for this location.
- Any booth with a structured wall (meaning a continuous structure, fabric or otherwise, that encloses or divides an area of space) must have a **5 foot opening, from floor to ceiling, in between every 20 feet of wall space. Walls cannot exceed 16 feet in height.**
- If using a non-official contractor to set-up and/or dismantle your exhibit, the required form to request for set-up by non-official contractor along with the Certificate of Insurance naming the Official General Contractor as an additional insured, must be received by the specified deadline in the Exhibitor Manual. Otherwise labor will have to be hired from the General Contractor by the non-official contractor in order for them to supervise your exhibit. These stipulations are strictly enforced to protect you, show management and the General Contractor.

EXHIBIT BOOTH EXAMPLES

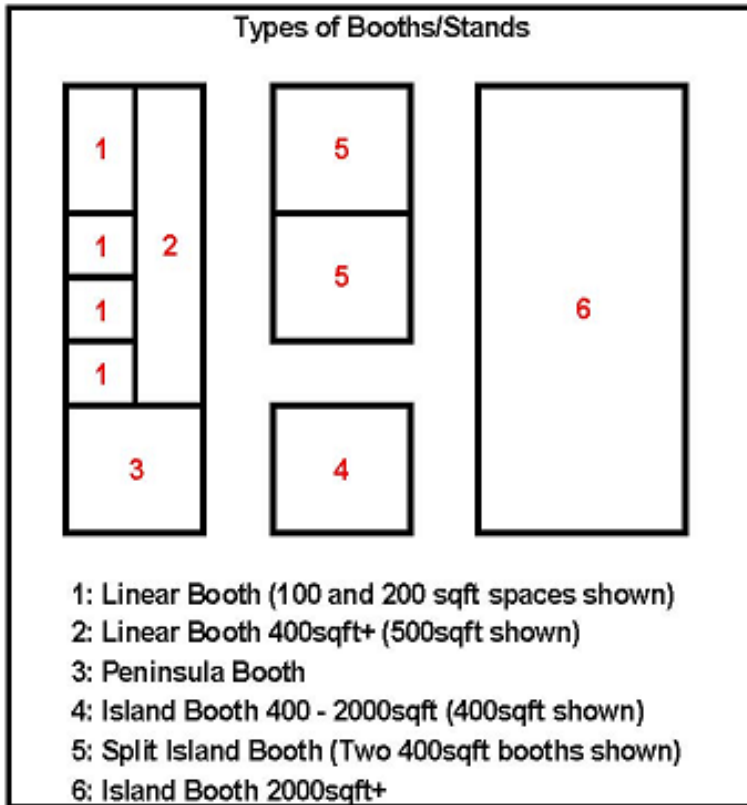

Linear Booth (in-line booth)

Linear Booths have only one side exposed to an aisle and are generally arranged in a series along a straight line. They are also called “in-line” booths.

Dimensions

To maintain consistency and for ease of layout and/or reconfiguration, floor plan design in increments of 10 feet (3.05m) has become the standard. Therefore, Linear Booths are most commonly 10 feet (3.05m) wide and 10 feet (3.05m) deep (10'x10'). Maximum backwall height limit: 8 feet (2.44m)

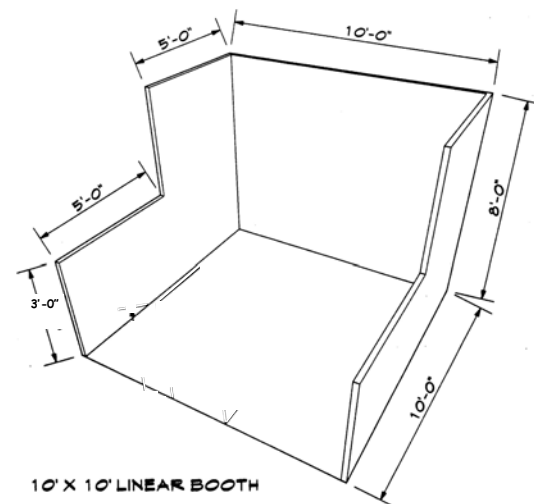

Use of Space

Regardless of the number of Linear Booths utilized, display materials should be arranged in such a manner so as not to obstruct sight lines of neighboring exhibitors. The maximum height of 8 feet (2.44m) is allowed only in the rear half of the booth space, with a 3 feet (0.91m) height restriction imposed on all materials in the remaining space forward to the aisle. Please contact your exhibit services managers regarding any equipment or display that will be higher than 8 feet

Corner Booth

A Corner Booth is a Linear Booth exposed to aisles on two sides. All other guidelines for Linear Booths apply.

Endcap Booths

An Endcap Booth is exposed to aisles on three (3) sides and is backs up to Linear Booths

Dimensions

An Endcap Booth is usually 10'x20'. When an Endcap Booth backs up to two Linear Booths, the backwall is restricted to 3 feet (0.91m) high within 5 feet (1.52m) of each aisle, permitting adequate line of sight for the adjoining Linear Booths. The middle 10ft of wall is still allowed to go up to 8 feet high.

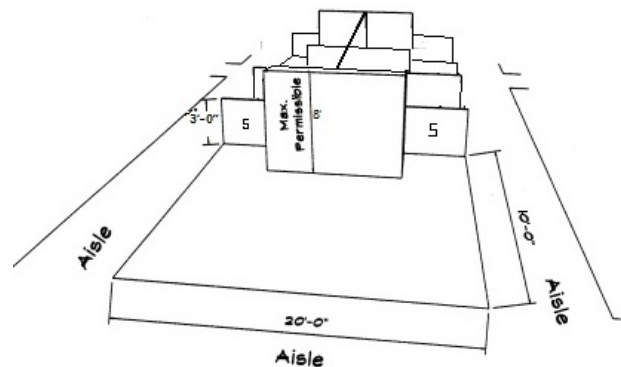

Perimeter Booth

A Perimeter Booth is simply a Linear Booth that backs to a wall of the exhibit facility rather than to another exhibit.

Dimensions and Use of Space

All guidelines for Linear Booths apply to Perimeter Booths except that the typical maximum backwall height is 12 feet (3.66m).

Peninsula Booths

A Peninsula Booth is exposed to aisles on three (3) sides and composed of a minimum of four (4) 10'x10' booths. There are two types of Peninsula Booths: (a) one which backs up to Linear Booths, and (b) one which backs to another Peninsula Booth and is referred to as a "Split Island Booth."

Dimensions

A Peninsula Booth is usually 20'x20' (6.1m x 6.1m) or larger. When a Peninsula Booth backs up to two Linear Booths, the backwall is restricted to 3 feet (0.91m) high within 5 feet (1.52m) of each aisle, permitting adequate line of sight for the adjoining Linear Booths. The center 10 feet can still go up to 16' feet high.

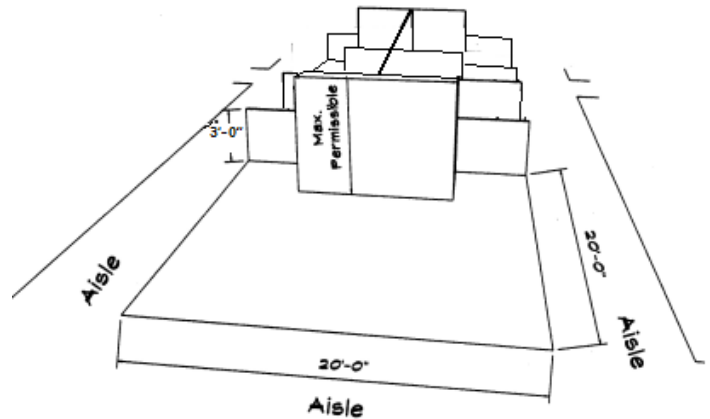

Overhead Signs

See *Hanging Signs & Graphics Height Restrictions* (pg. 6) for more information.

Split Island Booth

A Split Island Booth is a booth which shares a common backwall with another booth. The entire cubic content of this booth may be used, up to the maximum allowable height, without any back wall line of sight restrictions. 16 feet (4.88m) is a typical maximum height allowance, including signage.

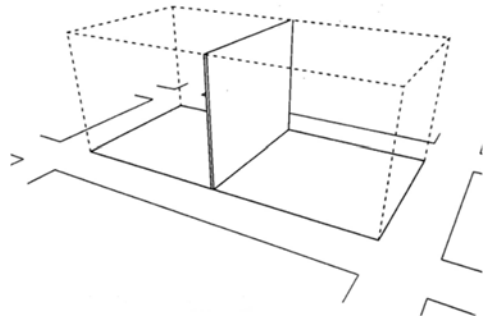

Island Booth

An Island Booth is any size booth exposed to aisles on all four sides.

Use of Space

The entire cubic content of the space may be used up to the maximum allowable height. **Booth Height** extending from floor to ceiling cannot exceed 16 feet (including drapery or structural walls). For information on overhead signs, see *Hanging Signs & Graphics Height Restrictions* (pg. 6).

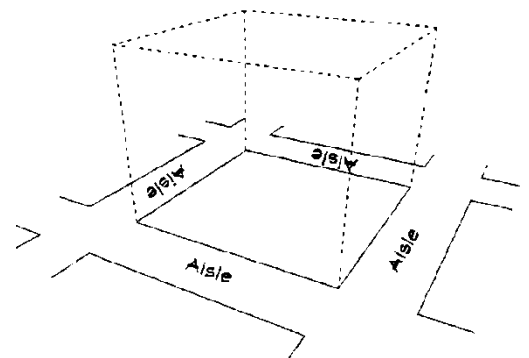

Other Important Considerations

Aisles

All aisles must be clear of exhibits. Interviews, demonstrations, and distribution of literature must be made inside Exhibitor's booth.

Balloons (Statics and Controlled)

Balloons filled with helium or hydrogen are not permitted (tethered or un-tethered, controlled or stationary). Balloons filled with air may be suspended from the ceiling in exhibits with a minimum size of 400 square feet (36sqm), **pending Venue approval**. In this instance, these will be treated as hanging signs. Please refer to hanging sign rules in this document for additional information. This should be designed so that the balloon is stationary and will not sway in the airflow of open doors or air conditioning.

• *Other guidelines may apply depending on the individual Venue Rules and Regulations.*

Booth Backwall Overview

The standard booth height limit at the Exhibition is eight (8) feet, but this limitation is also determined by Exhibitor's booth size and location on the floor. The following chart will show the acceptable heights. **However, any exhibit exceeding eight (8) feet in height (including signs) must be approved by PennWell regardless of booth size or location.** If an Exhibitor desires to exceed the standard heights or has booth space consisting of 2,500 square feet or more, the exhibitor **must submit** a request in writing along with the booth design and dimensions of the proposed booth for approval to Danielle McCloud at daniellem@pennwell.com.

All height restrictions are subject to physical limitations of the Exhibition hall. Prior to construction, Exhibitor has the responsibility to check on height capabilities for Exhibitor's assigned location.

<u>Inline Booth</u> 8'	<u>Perimeter Booth</u> <u>(against a wall)</u> 12'	<u>Peninsulas</u> 8'	<u>LOS Island Booth</u> <u>(aisles on all sides)</u> 22' floor to ceiling (Including Draping or structural walls) (excluding aerial ladders)	<u>ICC Island Booth</u> <u>(aisles on all sides)</u> 16" floor to ceiling
---------------------------	--	-------------------------	--	---

Booth Number

A booth number must appear on all specially-built backwalls. No signs are allowed above the permissible backwall height.

Booth Storage/Unightly Booths

Materials may be stored behind your booth during the show however all materials stored must be masked/covered so they are not visible. A drape or cover may be ordered through the General Services Contractor.

Any unsightly booth areas must be masked off by Exhibitor. This is commonly done with drape. PennWell, in its sole discretion, will determine whether or not booths are unsightly or have unsightly areas

Canopies and Ceilings

Canopies, including ceilings, umbrellas and canopy frames, can be either decorative or functional (such as to shade computer monitors from ambient light or for hanging products). Canopies for Linear or Perimeter Booths should comply with line of sight requirements (see "Use of Space for Linear or Perimeter Booths").

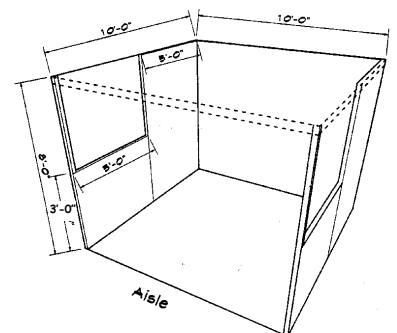

The base of the Canopy should not be lower than 7 feet (2.13m) from the floor within 5 feet (1.52m) of any aisle. Canopy supports should be no wider than three inches (3"). This applies to any booth configuration that has a sightline restriction, such as a Linear Booth. Fire and safety regulations in many facilities strictly govern the use of canopies, ceilings and other similar coverings. Check with the appropriate local agencies prior to determining specific exhibition rules.

Carpet

Exhibitor must carpet its booth(s) or use other floor covering. Concrete floor may not be exposed.

Columns

Exhibits with a full column in the booth area may utilize the column to enhance the booth design, provided fire cabinets and strobe lights remain visible and accessible. Column widths vary in size and PennWell recommends that Exhibitor contact its Exhibitor Services Manager if Exhibitor has any questions. Exhibitor may use the columns to the maximum height within the perimeter of the booth only. Consult with Mary Ericson mericson@bredeallied.com with Brede for specific measurements and location of columns prior to installation.

Note: Columns with fire hoses will require special attention so that fire hoses remain accessible

Compliance with Laws

Exhibitor shall observe and abide by all applicable federal, state, and local laws, codes, ordinances, rules, and regulations, as well as all rules and regulations of PennWell and the Exhibition hall. Exhibitor shall conduct itself, and shall require its agents, employees, independent contractors, and representatives, to conduct themselves, at all times in accordance with customary standards of decorum and good taste in the industry.

Copyrighted Materials

Exhibitor agrees not to play, broadcast, perform, or distribute any copyrighted material owned by others without first obtaining (at its own expense) all necessary rights and licenses and paying in full all required royalties or other fees.

Electrical

- All 110-volt wiring should be grounded three-wire.
- Wiring that touches the floor should be "SO" cord (minimum 14-gauge/three-wire) flat cord, which is insulated to qualify for "extra hard usage."
- Cord wiring above floor level can be "SJ" which is rated for "hard usage."
- Using zip cords, two-wire cords, latex cords, plastic cord, lamp cord, open clip sockets, and two wire clamp-on fixtures is not recommended and is often prohibited. Cube taps are prohibited.
- Power strips (multi-plug connectors) should be UL approved, with built-in over-load protectors.

Exhibit Activities/Demonstrations

"Live" demonstrations and costumed characters for the purpose of promoting Exhibitor's products will be permitted on the Exhibition floor **only within the confines of Exhibitor's booth** as long as it's pre-approved by show management. Any activities taking place on the exhibit hall floor without show management approval must be **ceased immediately** upon show management notification.

Exhibit Space Lighting & Sound

Without exception, all light and sound must be contained within, and directed into, the footprint of the contracted exhibit space including apparatus lights and/or sirens. Additional lighting may be brought in for the exhibit space; however this lighting must be restricted to the contracted exhibit space. Lighting should not shine onto the aisles or into a neighbor's exhibit space. An audiometer may be used to measure sound levels. * **Max sound level is 75 decibels**

Flammable and Toxic Materials

All materials used in display construction or decorating should be made of fire retardant materials and be certified as flame retardant. Exhibitors should be aware of local regulations regarding fire/safety and environment which must be adhered to. Exhibitors should dispose of any waste products they generate during the exhibition in accordance with guidelines established by the Environmental Protection Agency and the facility.

Hanging Signs & Graphics Height Restrictions

Hanging signs and graphics may be permitted in Peninsula and Island Booths 400 square feet or more with Show Management and Venue approval. Approval for the use of Hanging Signs & Graphics should be received from Show Management no less than 90 days prior to installation. Drawings must be available for inspection.

In **Lucas Oil Stadium**, exhibitors may not hang a banner or sign from an aerial or truss that is higher than **22 feet** from floor to the top of the sign.

In **Indiana Convention Center**, any banner or sign above the booth hung from aerial ladders or rigged above the booth cannot exceed **22 feet** from the floor to the top of the sign.

Please note: a truss is considered an extension of the ceiling.

Whether suspended from above or supported from below, they should comply with all ordinary use-of-space requirements per the specific Venue Rules and Regulations (for example, the highest point of any sign should not exceed the maximum allowable height for the booth type)

Installation

All Exhibitor displays must be completely installed within the time designated by PennWell for this purpose.

Limited License in Exhibitor's Name

Exhibitor grants to PennWell a fully-paid, perpetual, worldwide, non-exclusive license to use, display, and reproduce (in print, electronically, or otherwise) Exhibitor's name, trade names, logos, and product names in any listing of those companies exhibiting at or registered to exhibit at the Exhibition and in Exhibition promotional materials. In addition, Exhibitor authorizes PennWell to take photographs of Exhibitor's booth, exhibit, and staff during, before, or after the Exhibition and to use such photographs for any legitimate promotional purpose of PennWell.

Multi-story Exhibit

A Multi-story Exhibit is a booth where the display fixtures exceed 12 feet (3.66m), including Double-decker and Triple-decker Booths. The city building department needs to issue a building permit based on an application and drawings prepared and submitted by a licensed architect or engineer. Exhibitors should obtain local building regulations early on to ensure that all time constraints are met.

These types of booths require approval from the following:

- PennWell Show Management to ensure compliance with display rules
- Brede Allied to ensure that there are no physical obstructions that will create problems during setup
- The exhibit facility and/or relevant local government agency because it is deemed to be a "structure" for building purposes.

The rules set in place by convention centers and their local fire marshals vary from city to city with regards to the level of fire alarms, sprinklers, extinguishers, etc., that are required in multi-story booths. Stamped engineering drawings will need to be submitted for approval by the fire marshal, PennWell, and the General Service Contractor (Brede) will need a copy of the approved booth on file before booth construction may commence.

• Please contact PennWell Show Management for additional information and if possible include drawings or renderings of the proposed design. Show Management will determine if the proposed design works with our display rules and will forward the design to the show's General Service Contractor. The Contractor will work with the local fire marshal to give structural approval of the design.

No Assignment

Exhibitor understands and agrees that it may not assign the Agreement, in whole or in part, or any rights thereunder to any third-party without the prior written permission of PennWell. In addition, Exhibitor is not authorized and has no right to sublet any portion of its exhibit space or booth without the prior written permission of PennWell.

Smoke/Fog Machines

The use of fog machines inside the building is only allowed if it is water based. The use of any chemicals is strictly not allowed.

Structural Integrity

All exhibit displays should be designed and erected in a manner that will withstand normal contact or vibration caused by neighboring exhibitors, hall laborers, or installation/dismantling equipment, such as fork- lifts. Displays should also be able to withstand moderate wind effects that may occur in the exhibit hall when freight doors are open. Exhibitors should ensure that any display fixtures such as tables, racks, or shelves are designed and installed properly to support the product or marketing materials to be displayed

Towers

A Tower is a freestanding exhibit component separate from the main exhibit fixture. The height restriction is the same as that which applies to the appropriate exhibit configuration being used.

Towers in excess of 8 feet (2.44m) must have drawings available for inspection and have Show Management and Venue approval. Fire and safety regulations in many facilities strictly govern the use of towers. A building permit may be required.

Use of Unmanned Aircraft Systems (UAS) inside Venue

Any and all proposed UAS use by an exhibitor in the venue must be pre-approved by PennWell and the venue no later than thirty (30) days before the first day of the event and the operation of all drones must comply with the following rules.

- Visual Line of Sight must be maintained, and is defined as: unaided (corrective lenses and/or sunglasses accepted) visual contact between a pilot in command and an unmanned aircraft sufficient to maintain safe operational control of the aircraft
- The pilot in command (PIC) must hold either an airline transport, commercial, private, recreational, or sport pilot certificate.
- Prior to starting operations, the pilot must provide a Certificate of Insurance in a form acceptable to PennWell
 - Exhibitor will be responsible for all personal injury or property damage caused by the operation of the UAS. Exhibitor's Liability Insurance shall include a rider to cover all UAS activity
- To obtain pre-approval the exhibitor must disclose the nature and frequency of UAS use and provide the operating specifications of all UAS to be flown.
- All Unmanned Aircraft Systems must be operated in a safe and reasonable manner
- PennWell or the venue may require a fire watch depending on the proposed use of the UAS. The costs of any fire watch shall be prepaid by Exhibitor.
- UAS operation is subject to the same restrictions of video on the Exhibit Floor as stated in the terms and conditions of the Exhibit Space Agreement
- UAS use is subject to additional Venue rules and regulations
 - All UAS use shall comply with all applicable federal and other laws
 - Exhibitor shall defend and indemnify PennWell from all claims, suits, damages, judgments, or losses, of any kind made by any third party relating to the Exhibitor's use of drones and such indemnification shall include PennWell's reasonable attorney's fees.

Any exhibitor in violation of the Use of Unmanned Aircraft Systems Policy will immediately cease and desist operation of the UAS and may be subject to further governing body sanctions. Furthermore, if the prior approved use is deemed by PennWell, at its sole discretion, to be a nuisance to other exhibitors or attendees, PennWell may prohibit or otherwise restrict the use of the UAS. Exhibitor agrees that PennWell's decisions and discretion in such matter are final.

Use of Unmanned Aircraft Systems (UAS) outside or in National Airspace

Any and all proposed UAS use by an exhibitor must be pre-approved by PennWell and the venue no later than thirty (30) days before the first day of the event and the operation of all drones must comply with the following rules.

- Any operation that does not meet the statutory criteria for a public aircraft operation is considered a civil aircraft operation and must be conducted in accordance with all FAA regulations applicable to the operation. There are presently two methods of gaining FAA authorization to fly civil (non-governmental) UAS:
 - Section 333 Exemption**
 - Special Airworthiness Certificate (SAC)

- Visual Line of Sight must be maintained, and is defined as: unaided (corrective lenses and/or sunglasses excepted) visual contact between a pilot in command and an unmanned aircraft sufficient to maintain safe operational control of the aircraft
- The pilot in command (PIC) must hold either an airline transport, commercial, private, recreational, or sport pilot certificate. The PIC must also hold a current FAA airman medical certificate or a valid U.S. driver's license issued by a state, the District of Columbia, Puerto Rico, a territory, or the Federal government
- Prior to starting operations, the pilot must provide a Certificate of Insurance in a form acceptable to PennWell
- Exhibitor will be responsible for all personal injury or property damage caused by the operation of the UAS. Exhibitor's Liability Insurance shall include a rider to cover all UAS activity
- To obtain pre-approval the exhibitor must disclose the nature and frequency of UAS use and provide the operating specifications of all UAS to be flown.
- All Unmanned Aircraft Systems must be operated in a safe and reasonable manner PennWell or the venue may require a fire watch depending on the proposed use of the UAS. The costs of any fire watch shall be prepaid by Exhibitor.

Vehicles for Indoor Displays

Vehicles to be displayed indoors must adhere to the following guidelines and display will likely be inspected on-site by the local fire marshal.

- Gas tank must be less than ¼ full.
- Battery must be removed or disconnected.
- Gas tank must feature a locking cover or cover sealed with tape.
- Ignition keys removed.
- Propane or similar compressed gas tanks removed.
- A fire extinguisher must be present in any booth featuring a display vehicle.
- All exhibitors must ensure that all equipment, vehicles, signs, banners, or decorations are within leased booth space without exception, including vehicle bumpers, hitches, mirrors, and vehicle doors that are open during display. Exhibitors must ensure the booth space leased accommodates all equipment fully within booth space.
 - *Other guidelines may apply depending on the individual Venue Rules and Regulations.*

Water

Outside exhibitors needing water from the hydrant will need to obtain a temporary use permit and meter form from the Indianapolis Water Company. Please visit <http://www.citizensenergygroup.com/My-Service/PermitsandForms.aspx> to access the forms.

The following pictures represent unsightly booth storage and booth displays that are not allowed.



Examples of unsightly booth storage



Example of conducting business outside of exhibit space



Example of unauthorized storage & exposed backwall. Backwalls should be dressed in plain or neutral color(s).